

# An Architecture for Local Energy Generation, Distribution, and Sharing

Mike M. He, Evan M. Reutzler, Xiaofan Jiang, Randy H. Katz, Seth R. Sanders, David E. Culler, Ken Lutz

EECS, UC Berkeley, 253 Cory Hall, Berkeley, CA, mikehe@eecs.berkeley.edu

***Abstract** - The United States electricity grid faces significant problems resulting from fundamental design principles that limit its ability to handle the key energy challenges of the 21<sup>st</sup> century. We propose an innovative electric power architecture, rooted in lessons learned from the Internet and microgrids, which addresses these problems while interfacing gracefully into the current grid to allow for non-disruptive incremental adoption. Such a system, which we term a “LoCal” grid, is controlled by intelligent power switches (IPS), and can consist of loads, energy sources, and energy storage. The desired result of the proposed architecture is to produce a grid network designed for distributed renewable energy, prevalent energy storage, and stable autonomous systems. We will describe organizing principles of such a system that ensure well-behaved operation, such as requirements for communication and energy transfer protocols, regulation and control schemes, and market-based rules of operation.*

## I. INTRODUCTION

The electric grid in the United States faces numerous challenges for effective power delivery in the 21<sup>st</sup> century. As growth of demand continues, it becomes increasingly difficult to retrofit an aging system to supply sufficient power with an adequate margin for maintaining stability while meeting contingencies [1, 2]. Furthermore, power systems must be sized to handle peak demand levels, which are significantly higher than average demand and may be reached only a few hours a year [3]. Unfortunately, growth in peak demand has continued to outpace growth in transmission capacity over the last 20 years, as shown in Fig. 1 [1]. In addition to aggregate power problems, specific corridors that have seen disproportionate increases in demand are becoming especially congested [4]. These problems are exacerbated by the fact that the challenge of successfully delivering power has in general become more difficult as the size and complexity of the system has grown [5].

The current architecture of the power grid also poses problems for generating a significant portion of our energy needs from renewable sources. The grid was designed for central, large-scale, predictable power sources such as coal, natural gas, and nuclear power plants and is not able to accommodate high penetration of intermittent sources without drastically sacrificing stability [6]. The maximum amount of intermittent sources that can be utilized is estimated to be about 20% to 25% of total demand using established control methods [7], though certain methods of operation may increase this limit, such as forecasting [8] and

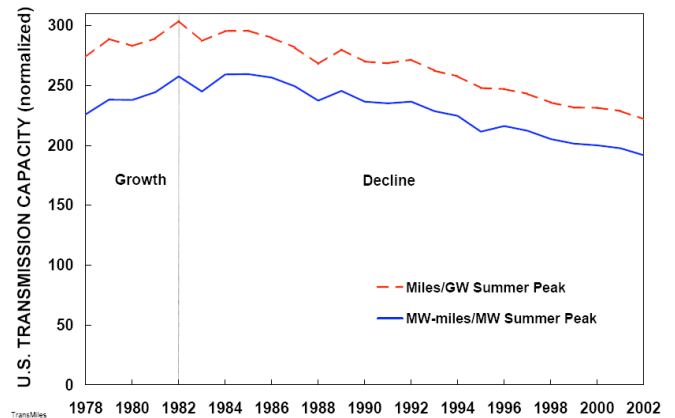

Fig. 1. Normalized US Transmission Capacity  
Source: Edison Electric Institute

balancing with demand response capabilities [9]. This poses a fundamental challenge to the integration and penetration of renewable sources in the future. Furthermore, the distribution system is designed for one-way power flow – from central power plants to distributed loads [10]. The introduction of a large number of distributed sources, such as photovoltaic cells on residential roofs, is not easily manageable and adds to stability liabilities in the operation of the grid. [6, 10].

These problems cannot be easily solved under the current electric grid paradigm. Building additional transmission capacity is costly, time-consuming, and fraught with politics [11]. Expanding the current system will, in the long run, only increase its complexity. Short of a costly radical restructuring of the grid, its architecture remains one of the principal barriers to achieving the levels of renewable energy penetration that are necessary to meet long term energy goals.

## II. THE LoCal GRID

We introduce the “LoCal” grid as a system architecture designed to address the aforementioned problems in the current grid while interfacing gracefully to allow non-disruptive incremental adoption. At its core, a LoCal grid is a connected group of loads, energy sources, and energy storage that intelligently manages its own power needs and interfaces to external power systems in a well-behaved manner. A LoCal grid is designed to operate either independently, connected to the electric grid, and/or to other LoCal grids without affecting its ability to provide power to its users.

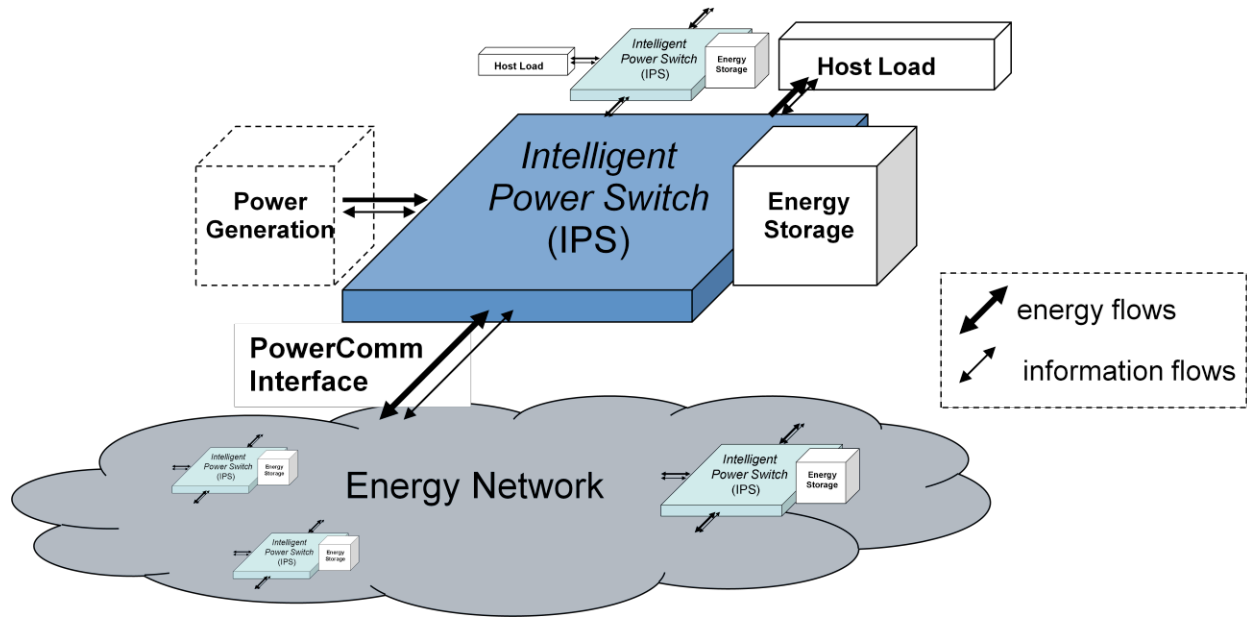

Fig. 2. LoCal Architecture Schematic

A LoCal grid operates as an intelligent, autonomous power system. It supplies its loads as needed, generates power when able, and stores excess energy to facilitate energy transfer processes. Energy generation and storage can be sized to accommodate the average power consumption and expected variations of the load. With sufficient energy storage to buffer variations in load and generation, a LoCal grid can present itself as a black box to the external grid, appearing as a constant load, a constant source, or as a zero load, thereby simplifying its impact on the electric grid. Critically, this enables the use of intermittent sources, such as most renewable energy sources, without the negative impacts on stability of a directly connected intermittent source. On an individual level, a LoCal grid operates much like a microgrid.

More significantly, a LoCal grid can operate as a controllable source or load. The presence of energy storage allows a LoCal grid to moderate its energy imports from the grid in response to market signals, adding demand response capability, or to perform peak-shaving for the grid at a profit by importing energy at low cost, low demand times and exporting energy at high cost, high demand times.

### A. LoCal Networks

An important characteristic of the LoCal grid is the ability to easily connect with the electric grid or with other LoCal grids to form ensemble networks. By design, such networks can utilize the combined generation and storage capabilities of individual nodes to improve aggregate performance. The ability of LoCal nodes to easily form networks allows this architecture to incrementally overlay the current electric grid to produce a distributed system of local generation and distribution.

The LoCal architecture is designed to accommodate applications of different sizes, from individual electrical

devices to home, neighborhood, or municipal scales, though components may be radically different at different scales. This allows LoCal networks to contain hierarchies and various network configurations. An entire network of LoCal nodes can be isolated from the external electric grid behind a larger enveloping LoCal grid, thereby allowing a community of LoCal nodes to operate as a single independent entity from the perspective of electric utilities. For example, a group of LoCal nodes comprised of individual homes may choose to be further encapsulated within a larger neighborhood level LoCal grid. Furthermore, there is no requirement for any specific network topology; for example, tree, bus, mesh and star arrangements may all be used based on the needs of the application.

### B. Network Principles

The networking concepts of LoCal grids are based on ideas derived from the design principles of the Internet. Intelligence and management are shifted to the ends of the system (the End-to-End principle), allowing rapid expansion and high levels of complexity without the increasingly difficult and costly limitations of a centrally controlled system. The unrestricted diversity of the underlying implementation of LoCal nodes is encapsulated by well-defined communications and power interfaces between nodes (the Narrow Waist Model).

The LoCal architecture is based on principles of service displacement and coexistence. Services currently provided by the electric grid can be displaced by LoCal grids, but LoCal grids are implemented as an overlay that coexists with current infrastructure rather than producing its obsolescence. In fact, the electricity grid has an important role in providing an assured level of reliability in the early stages of adoption of a

LoCal grid, and can continue to provide power and backbone infrastructure to more developed LoCal networks.

The LoCal network is fundamentally a peer-to-peer technology, rather than a client-server technology as is the case in the traditional electric grid. A peer-to-peer network can achieve greater levels of overall reliability, as is the case with the Internet. While local outages may occur for specific nodes, the peer-to-peer model guarantees that no large scale outages occur. In the case of faults at a LoCal node, further disruption can be prevented by isolation from neighboring nodes and the use of stored energy.

We also introduce the concept of “packetized energy” – the routing of energy between nodes to meet needs. LoCal networks are designed as vehicles of cooperation; sharing of energy resources is an integral part of operation. The routing of energy between nodes is necessary for cooperative behavior of a network. This allows a network to utilize the resources that are most plentiful at any point in time. For example, nodes that have wind generation may sell energy at times of high production, but may buy energy from other nodes at times of low production. Nodes may also choose to oversize storage or generation capacities to act as an energy vendor for profit. It should be noted that routing of energy in LoCal grids is only true in an accounting sense; only the net flow of energy is important. It is neither possible nor necessary to track individual units of energy through a network.

An essential part of the LoCal network is a communications system that exists in a parallel layer with the power system. Communication between nodes is necessary to coordinate transfers and to meet aggregate energy needs of an ensemble network. A robust peer-to-peer communications network is also necessary to convey market signals effectively to facilitate the economics of transactions between nodes. Wired, wireless, and power line communications may all be used to suit particular applications.

### *C. Intelligent Power Switch*

A key architectural building block in a LoCal grid is the Intelligent Power Switch (IPS). An IPS combines communications with a power electronic interface to manage the link between any particular LoCal grid and external grids. The IPS is responsible for controlling power flows to ensure reliable operation of its LoCal grid. In some sense, an IPS combines the capabilities of an Internet router with that of power conversion and protection equipment.

The primary purpose of an IPS is to provide a well-defined interface between nodes, abstracting the diversity of possibilities for underlying implementations. The IPS thus provides plug and play capability to the LoCal grid. This uniform interface allows nodes to have the same level of interconnectivity to different nodes without sacrificing functionality. Different voltage and power levels may still be used for energy transfer, depending on the application, but the IPS standardizes these interactions. The IPS is the enabler

of the network capabilities that are fundamentally important for the advantages of LoCal grids.

The hardware form of an IPS depends on the scale of the LoCal application that it serves. For example, an IPS can replace the UPS or power supply of a computer, the grid tie inverter of a solar power installation, or operate like a substation for a neighborhood. The exact implementation is unspecified; of greater importance is that the IPS conforms to the communications and power conversion standards of the LoCal architecture.

The power management system of a LoCal grid, responsible for monitoring and ensuring a sufficient level of stored energy and moderating loads, generation, and external power flows, may be integrated with an IPS, or can be a separate component that acts as a controller.

### *D. Energy Storage*

Energy storage technology is a key enabler of the LoCal architecture and remains one of the biggest technological challenges. Long working lifetimes, high round-trip efficiencies, and low cost on a power and energy basis are critical for a LoCal grid application, since such a device is expected to see frequent utilization. Energy density and power density are usually of secondary importance for most applications, since LoCal applications are intended to be stationary. Significant research and development is still needed to improve performance of energy storage technologies.

Energy storage technologies must be matched to the intended application. Conventional electrochemical batteries are largely inadequate for applications with higher levels of power flows due to limited charge/discharge cycles and high costs, but may be appropriate for electronic device scale nodes or other smaller applications. Flow batteries show greater promise than conventional batteries for utility and large scale applications where energy density is not a limiting factor. Flywheel storage technology may be useful for power quality management and short term, high power storage. Thermal energy storage is promising for medium residential level to large scale applications given low costs, high power density, and practically unlimited lifetimes. Furthermore, thermal energy storage can be naturally paired with solar thermal generation to further increase utility. Certain geographically-contingent energy storage technologies, such as pumped hydro or compressed air, are good candidates for large scale storage when available. Future development of novel energy storage technologies may yield other promising candidates.

Local fuel-based generation can in fact act as a form of energy storage and balance intermittent sources to aid renewable penetration. While storage of electrical energy is not possible with fuel-based generation alone, many of the same benefits provided by energy storage can be attained. Use of fuel-based generation represents a possible implementation of the LoCal architecture in the absence of

practical energy storage solutions, and in addition may provide practical benefits in conjunction with energy storage.

### *E. Incremental Adoption*

The high costs associated with improving or expanding the current electric grid infrastructure make large scale restructuring impractical. Changing the current electricity grid to one that is more amenable to intermittent or distributed sources requires modification of physical infrastructure. Unfortunately, modifications toward a different power delivery paradigm are difficult to implement incrementally due to the fact that each modification impacts other parts of the grid.

The LoCal architecture is designed to be fundamentally non-disruptive to the electric grid, allowing for incremental adoption. The model for adoption is that of an overlay on top of existing electric grid infrastructure. LoCal grids are not designed to compete with or displace existing grid infrastructure; in fact, at early levels of adoption, LoCal grids rely on existing infrastructure to provide a baseline level of reliability and service. This method of overlaying existing infrastructure parallels the development of the Internet on top of existing telecommunications systems and provides for easier incremental expansion with lower cost.

Additionally, it is important for LoCal grids to provide benefits at low levels of adoption. At low levels of adoption, the formation of LoCal networks may not be plausible due to lack of other LoCal peers and minimal additional advantages if only a few peers are available. This represents a radically different operating regime than in the case of a mature LoCal network as envisioned. In order to justify incremental adoption, a LoCal grid has to offer stand-alone benefits.

The benefits of a LoCal architecture can be separated into those inherent on a building block level and those dependent on network interactions. As an individual entity, a LoCal grid operates like and has all the benefits of a microgrid. For example, local energy storage allows purchasing of energy at off-peak times for cost savings, adds additional reliability, allows demand response without interruption of loads, and can smooth intermittent power outputs from renewable energy sources. These benefits must offset the costs of implementing a LoCal grid to justify adoption. This may initially be true for some applications but not for others.

With a higher density of LoCal grids, it becomes beneficial to create LoCal networks. Possible benefits including increased reliability and preferential utilization of the most advantageous energy resources of the network depending on current favorability. A plausible path toward implementation of a Local network for early adopters is that of a company or neighborhood already invested in individual LoCal grids choosing to consolidate infrastructure, increase internal reliability, or enable sharing for system-wide energy-use optimization.

Incremental adoption becomes progressively simpler in the presence of more mature LoCal networks. Plug and play

functionality allows new users to connect to existing networks easily and gain the benefits of the entire network of distributed resources. At high levels of penetration, LoCal grids can displace basic services traditionally provided by utilities, which may then evolve toward providing less overall power. Utilities and transmission infrastructure can continue to provide services related to long distance power sharing between LoCal networks.

## III. Protocols and Standards

A set of standards and protocols for LoCal grids needs to be enumerated to ensure predictable and well-behaved interaction between LoCal nodes and with the electric grid. Specific prescriptions for such standards are beyond the scope of this paper, but we will enumerate the issues that must be addressed in formulating standards and protocols for LoCal grid operation.

### *A. Interactions with the Electric Grid*

The goal for interactions between a LoCal grid and the electric grid is to provide for functionality in the LoCal grid without being disruptive to the wider electric grid. A LoCal grid is designed to appear no different than other loads from the perspective of the utility, and can be less disruptive than standard loads or even beneficial due to the buffering capabilities that energy storage provides. However, standards must be adhered to for power generated locally that is put on the grid and certain situations require careful management of interactions. For example, voltage and frequency levels must be kept within tolerances; and in case of islanding, a LoCal grid must not energize its local electric grid to ensure the safety of workers and to prevent damage to equipment. The set of standards enumerated in IEEE 1547 Standard for Interconnecting Distributed Resources with Electric Power Systems provides a good starting point for a more comprehensive standard for LoCal grids [13].

### *B. Interactions between LoCal Grids*

Standards for interactions between LoCal grids have to ensure proper non-disruptive behavior between peers while allowing for the interactions that provide the benefits of a LoCal network. Standards must exist for both power transfer and communications interactions.

Perhaps the key principle for peer to peer interaction is the preservation of autonomous operation. Even when connected to a network of peers. For example, LoCal nodes must accept denials or limits on energy transfer by other entities, while retaining the ability to deny or limit transactions itself. Each LoCal node should furthermore be able to disconnect from peers that do not meet these standards. This follows similar “do no harm” standards that accompany many electronic devices.

Power transfer standards will need to specify power characteristics such as AC or DC, voltage, and frequency levels. DC power may become a viable option for transmission of power between LoCal grids. It is not necessary to maintain identical internal standards between different LoCal grids, since each is isolated and abstracted from its peers. For example, local AC or DC distribution can be used, as well as different voltage levels or frequencies, to suit different applications, provided that external flows are standardized. DC distribution may be better suited for electronics and DC generation technologies like solar photovoltaic power, while AC distribution may be better suited for motors.

Communications standards can follow the path set by the Internet to provide a streamlined protocol for determining energy needs, supplies, and prices. Signals must also be routed across nodes, in a fashion similar to Internet routing, to ensure cooperation across a network. Communications in a LoCal network can be modeled after Internet communications protocols or even directly leverage Internet technology for communications.

A rigorous set of market rules is required to enable peer-to-peer transactions of energy as a commodity. Market signals and prices should be passed on by LoCal nodes to achieve large-scale market equilibria. Routing of packetized energy through multiple LoCal nodes requires strict accounting protocols to model the effective flow of energy. Electric utilities can provide real-time pricing data to LoCal grids to facilitate interactions between the two, as time-of-use market-based pricing arrangements already exist for some conventional loads [12]. Finally, protections are needed in developed LoCal networks to prevent any large entities from exercising market power over its peers.

#### IV. Advantages

The predicted benefits of the LoCal architecture can be roughly divided into two categories: those that are available to any individual LoCal grid and those that are the result of network interactions. Individual benefits closely approximate those of an intelligently managed microgrid system and are available even at low levels of adoption. Benefits derived from network cooperation are attainable in the long term, as density of adoption increases. The benefits of LoCal network architecture in the long term allow a fundamental shift in the paradigm of electric power delivery.

##### *A. Individual LoCal Benefits*

A fundamental motivation for LoCal grids is to provide a structure to enable simple deployment of intermittent renewable resources on a large scale. The combination of energy storage to buffer intermittent generated power and intelligent power switches to manage power flows enables a LoCal grid to integrate renewable sources smoothly and without disruption to the grid. By simplifying grid

integration, the LoCal architecture can remove one of the biggest barriers to widespread renewable energy adoption.

The benefits from individual LoCal grids include other commonly cited motivations for distributed generation and microgrids. By locating generation at the site of use, combined heat and power applications can greatly add to efficient use of energy resources. In addition, the incorporation of energy storage alone adds an additional level of premium reliability for customers. Furthermore, the presence of distributed generation and storage can also provide a measure of additional security [14] and reliability [15] to the wider electric grid.

The presence of energy storage and intelligent management of power needs allows LoCal grids to serve a number of roles for reducing the burden on the electric grid. First, they serve to level or time-shift the demand curve of integrated loads, reducing the level of peak demand on the system. On a large scale, this lessens the load on the generation, transmission and distribution systems, which are sized to accommodate peak demand and under the most stress during peak times, and reduces the need for peaking plants, which are significantly more expensive and less efficient than base load generation.

Second, LoCal grids can perform arbitrage on power prices, given a permissive regulatory framework, by buying additional energy at off-peak times to sell back to the utility at peak demand times. This provides profit for investors in energy storage and additionally reduces the load on transmission and distribution systems and the need for peaking plants.

Third, with intelligent power management at the load, LoCal grids can provide demand response capability based on energy prices on a large scale. Response to market signals is built in to the LoCal architecture both as a peer to peer interaction and as a reaction to market signals from electric utilities. The presence of energy storage furthermore allows shedding of demand from the perspective of the electric grid without actually disrupting loads. Both demand response and arbitrage allow LoCal grids to become “Good Samaritans” in the electric grid in addition to simply being non-disruptive peers.

Finally, individual ownership of energy resources and the presence of monitoring systems can heighten awareness of energy use patterns and increase personal motivations for conservation and efficiency. In addition, energy use monitoring systems can aid targeted conservation efforts by providing feedback on the utility of various efforts. Personal conservation, though not a technical part of the LoCal architecture, can have one of the most powerful effects on energy use.

##### *B. LoCal Network Benefits*

In the presence of a network of LoCal nodes, emergent properties are expected to provide additional benefits of collective behavior. Since each LoCal grid is individually

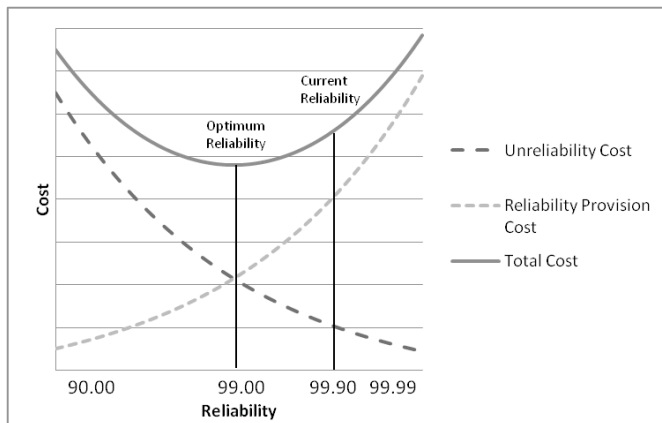

Fig. 3. Cost of Reliability Provision

intelligent and acts in the best interest of internal performance and reliability, an ensemble network of LoCal grids can approach economic models of perfect competition. As a collective network, this leads to the preferential utilization of plentiful and lower cost energy resources. The aggregate daily load curve of a LoCal network will tend to flatten due to market pressures, providing utilities with significant reductions in peaking needs. We believe that this represents a simpler and less disruptive path toward a market-based paradigm than conventional deregulation of utilities.

By changing the structure of the electric grid from one that is centrally managed to one that is distributed, LoCal grids can further add to the security and stability of the aggregate power system. Cooperative, autonomous and mostly self-sufficient LoCal grids operating as a network provide a fundamentally more reliable architecture than the present electricity grid. Shortages in generation or temporary spikes in load can be accommodated by the ensemble network, with each connected entity contributing additional buffering capability, while faults occurring in particular areas can be isolated automatically and intelligently. In much the same way that the distributed resources of the Internet guarantee that no large-scale outages occur, LoCal grids can also improve the reliability of power systems.

LoCal networks can displace certain services traditionally provided by utilities. The overall reliability of the electric grid is dictated by the needs of the loads which require the highest quality of power. This high level of reliability is only truly needed by this small subset of the overall consumer base, yet provision of base reliability adds significant system-wide costs that are supported by all consumers [16]. By displacing the reliability service traditionally provided by utilities, a LoCal network can reduce this cost for all users system-wide and instead allows consumers of high quality power to purchase additional reliability, either through the importing of power from peers or additional internal storage, generation, and redundancy (Fig. 3).

The LoCal network ultimately may provide a natural path for large groups of communities or business to become more self-sufficient with distributed renewable energy generation.

Certain services may be displaced by local resources, but electric utilities can continue to play an important role, for example, by providing generation with renewable technologies that are more effective on a large scale, such as wind power. A power system based on cooperation between centralized generation and distributed resources, facilitated by distributed intelligence at the ends, may be the most effective implementation of LoCal architecture.

## REFERENCES

- [1] Hirst, 2004 E. Hirst, U.S. transmission capacity: present status and future prospects, Edison Electric Institute, Washington, DC (August 2004).
- [2] Paul L. Joskow, Transmission policy in the United States, Utilities Policy Volume 13, Issue 2, Electricity Transmission, June 2005, Pages 95-115.
- [3] Summer 2007 Electricity Review, New York Independent System Operator, October 2007
- [4] Johnston, David Cay, "Grid Limitations Increase Prices For Electricity," The New York Times, December 13, 2006.
- [5] Grudin, Nikolai and Roytelman, Ilya, "Heading Off Emergencies in Large Electric Grids," IEEE Spectrum, April 1997
- [6] Kroposki, B., Margolis, R., Kuswa, G., Torres, J., Bower, W., Key, T., Ton, D., "Renewable Systems Interconnection: Executive Summary," National Renewable Research Laboratory, U.S. Department of Energy, Feb 1, 2008.
- [7] European Wind Energy Association, Large Scale Integration of Wind Energy in the European Power Supply: Analysis, Issues and Recommendations, December 2005
- [8] Rohrig, Kurt; Lange, Bernhard, "Improvement of the Power System Reliability by Prediction of Wind Power Generation," Power Engineering Society General Meeting, 2007. IEEE, vol., no., pp.1-8, 24-28 June 2007
- [9] Stadler, Ingo, "Power grid balancing of energy systems with high renewable energy penetration by demand response," Utilities Policy, Elsevier, vol. 16(2), pages 90-98, June 2008.
- [10] Driesen, J.; Katiraei, F., "Design for distributed energy resources," Power and Energy Magazine, IEEE, vol. 6, no. 3, pp.30-40, May-June 2008
- [11] Borenstein, Severin and James Bushnell. 2000. "Electricity Restructuring: Deregulation or Reregulation?" Regulation. 23:2, pp. 46-52.
- [12] "Power Smart Pricing," CNTEnergy, URL: <http://www.powersmartpricing.org/>
- [13] IEEE 1547 Standard for Interconnecting Distributed Resources with Electric Power Systems, IEEE, URL: [http://grouper.ieee.org/groups/scc21/1547/1547\\_index.html](http://grouper.ieee.org/groups/scc21/1547/1547_index.html)
- [14] Meyer, B., "Distributed Generation: towards an effective contribution to power system security," Power Engineering Society General Meeting, 2007. IEEE, vol., no., pp.1-6, 24-28 June 2007
- [15] Dialynas, E.; Hatzigiorgiou, N.D., "Impact of Microgrids on Service Quality," Power Engineering Society General Meeting, 2007. IEEE, vol., no., pp.1-5, 24-28 June 2007
- [16] Marnay, C., "Microgrids and Heterogeneous Security, Quality, Reliability, and Availability," Power Conversion Conference - Nagoya, 2007. PCC '07, vol., no., pp.629-634, 2-5 April 2007